

REV.	ECN NO.	DESCRIPTION	DESIGN	DATE
A		INITIAL	Kai	2018.03.29

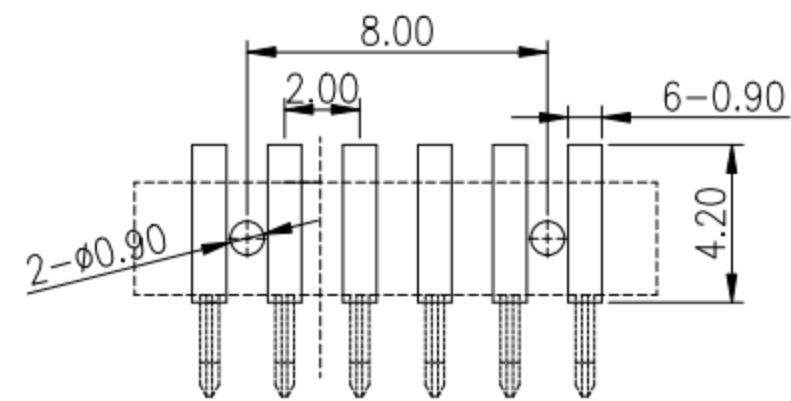

RECOMMENDED P.C.B LAYOUT
TOP VIEW (.XX±0.05)

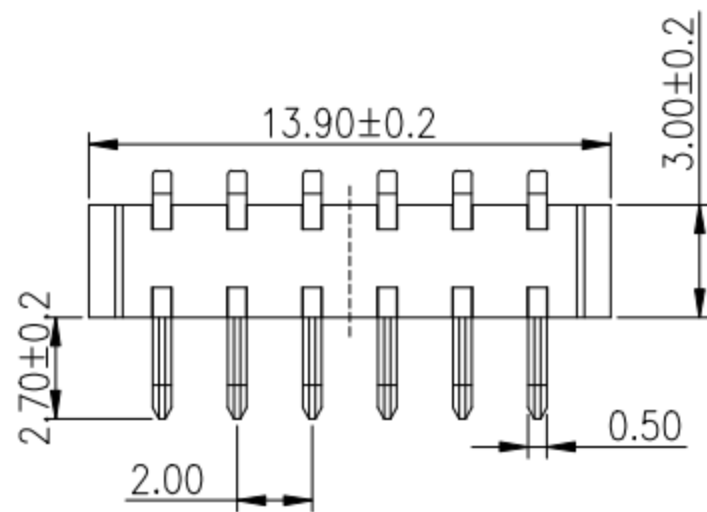
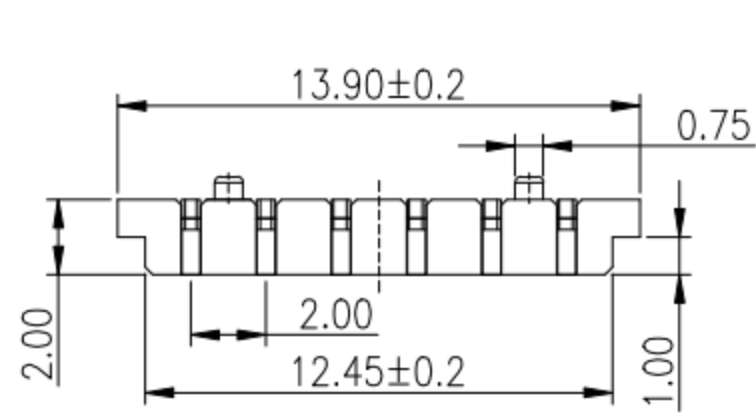
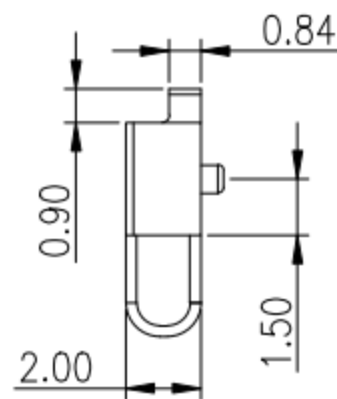
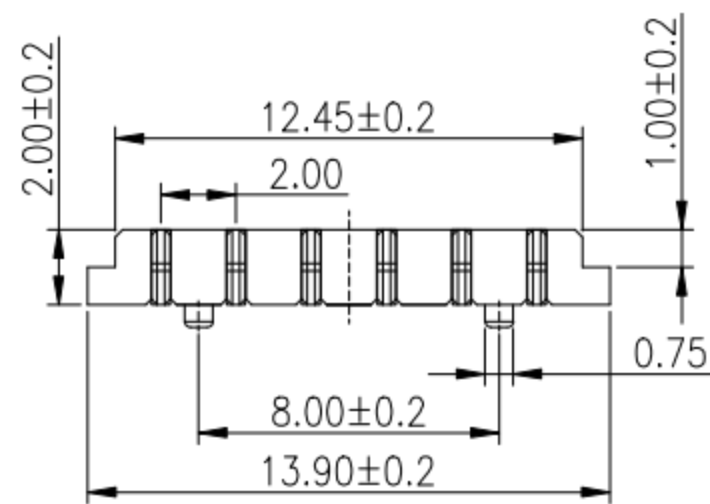

NOTE:

Material

Insulator:Nylon 9T(UL94V-0)

Contact:phosphor Bronze

Contact Plated:Gold over Nickel or Tin

Specification

Rated voltage: 12V 30V

Current rating: 3A 5A

instant CURRENT:7A

Contact Resistance:30MΩ

Insulation Resistance:100MΩ

Dielectric Voltage:1000V

Operdting Temperature:-40°~105°

UNLESS OTHERWISE SPECIFIED TOLERANCES

DECIMALS:		ANGLES:	
DIM	TOL	DIM	TOL
X.	±0.50	X.	±2°
X.X	±0.30	X.X	±1°
X.XX	±0.20	X.XX	---
X.XXX	±0.10	X.XXX	---

东莞市高迪电子有限公司

DWG NO.	PART NAME:
DESIGN:	PART NO.
CHECK:	REV. A
APPROVED	UNIT: mm
	SHEET: 1/1

②	HOUSING	1	LCP		BLACK
①	CONTACT A	2	PHOSPHOR BRONZE 0.20T	Au PLATED	
ITEM	PART NAME	Q'TY	MATERTAL	DESCRIPTION	REMARK